



TURNING MODULAR SYSTEM



POWERED BY HighT



D'ANDREA®
THE ART OF PRECISION

TURNING MODULAR SYSTEM



Golden Compass
award for industrial design



Lainate (Milan)



D'Andrea S.p.A. represents the headquarters of the group, based in Lainate, a few kilometers from Milan. With over 7.000 sqm, D'Andrea boasts a modern, functioning and efficient plant where several machine tools are involved in the production of Tools and Heads. In particular, the grinding operations as well as the final test and assembly are here carried out.



Castel Del Giudice (Isernia)



D'Andrea Molise was founded in 2001 in Castel Del Giudice (Isernia), where Marino - the founder, was born. In this plant, most of the semi-finished products are made and, subsequently, finished, mounted and tested in the headquarters.

THT TURNING MODULAR SYSTEM

SISTEMA DI TORNITURA MODULARE THT

The **THT** system comes from the patented **HT** coupling, which allows the composition of turning tools by combining the male component – available with various machine attachments (PSC, HSK...) – with the female component, the tool with various geometries.

By using a few elements, it is possible to create a wide variety of configurations, covering numerous applications: from heavy roughing to high-precision finishing, thanks to interchangeable heads compatible with both negative and positive ISO carbide inserts.

Flexibility, efficiency and cost savings

- The modularity of the THT system enables quick replacement of the cartridge alone in the event of breakage, preserving the tool body. This translates into reduced waste, shorter machine downtime, and more continuous and reliable production.
- A reduced number of components in stock makes it possible to achieve multiple tool configurations **while saving up to 75% of inventory**. This results in simpler, more efficient stock management and faster response to production needs.

Special solutions

The modular structure of the system also allows fast development of special solutions, ensuring high design flexibility and rapid turnaround for specific applications.

Il sistema **THT** nasce dall'attacco brevettato **HT** che permette di comporre utensili di tornitura unendo il componente maschio – disponibile con diversi attacchi macchina (PSC, HSK...) e quello femmina, ovvero l'utensile con varie geometrie.

Con pochi elementi è possibile creare numerose configurazioni, coprendo un'ampia gamma di applicazioni: dalla sgrossatura pesante alla finitura di precisione, grazie alle testine intercambiabili compatibili con inserti ISO, sia negativi sia positivi, in metallo duro.

Flessibilità, efficienza e risparmio

- La modularità THT consente di sostituire rapidamente la sola cartuccia in caso di danneggiamento, preservando il corpo utensile: meno sprechi, minori tempi di fermo macchina, continuità produttiva.
- Un numero ridotto di elementi a magazzino consente di ottenere numerose configurazioni diverse, con un **risparmio fino al 75% dello stock**. Questo si traduce in una gestione più semplice ed efficiente e in una maggiore rapidità di risposta alle esigenze produttive.

Soluzioni speciali

La struttura modulare del sistema consente anche la progettazione rapida di soluzioni speciali, garantendo elevata flessibilità e tempestività per applicazioni specifiche.

HighT (HT) COUPLING CONTACT SURFACES

ATTACCO HighT (HT) SUPERFICI DI CONTATTO

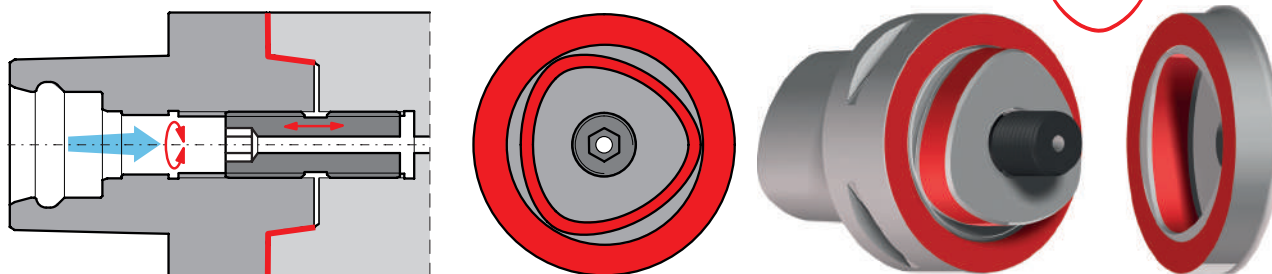

KEY FEATURES

- * Perfect coupling and high torsional strength, ideal for heavy turning operations.
- * Zero backlash, thanks to the pulling force exerted by the central drawbar.
- * Reduced overall dimensions in the tool assembly.
- * Proper axial coolant way.

CARATTERISTICHE

- * Perfetto accoppiamento ed elevata resistenza alla torsione, adatto a lavorazioni di tornitura pesanti.
- * Assenza di gioco, grazie alla forza di trazione esercitata dal tirante centrale.
- * Ingombri ridotti nella composizione dell'utensile.
- * Passaggio centrale del refrigerante.

HT SYSTEM ASSEMBLY

MONTAGGIO SISTEMA HT

A. Screw the locking screw (2) into the arbor (3) until it reaches the mechanical stop (d).

B. Insert the arbor (3) into the HT housing until the locking screw (2) makes contact (e) with the tool holder (1), check the correct phasing by aligning the reference markings (f).

C. Insert the hex key (4) into the arbor (3) and tighten the locking screw (2).

Fully tighten the locking screw (2) according to the clamping torque values specified in the table.

A. Avvitare la vite di bloccaggio (2) nel cono (3) sino alla battuta meccanica (d).

B. Inserire il cono (3) nella sede HT sino a quando la vite di bloccaggio (2) è a contatto (e) con il portautensile (1), verificare la corretta fasatura tramite l'allineamento delle marcature di riferimento (f).

C. Introdurre la chiave esagonale (4) nel cono (3) e avvitare la vite di bloccaggio (2).

Serrare a fondo la vite di bloccaggio (2) facendo riferimento ai valori di coppia in tabella.

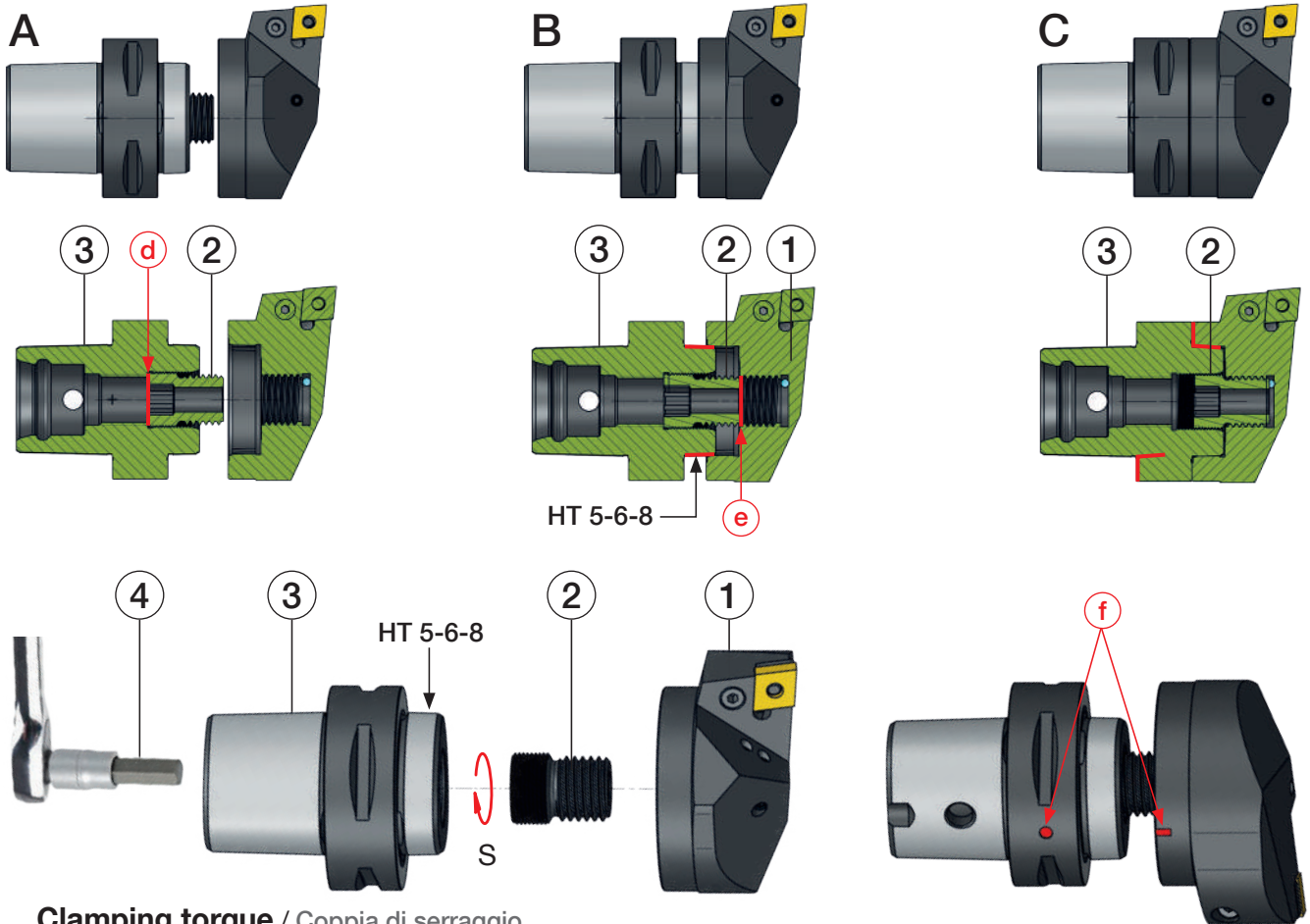

Clamping torque / Coppia di serraggio

HT	S	Nm	CODE 4
5	8	35 ÷ 40	101501608000
6	10	45 ÷ 50	101501610000
8	12	80 ÷ 90	101501612000

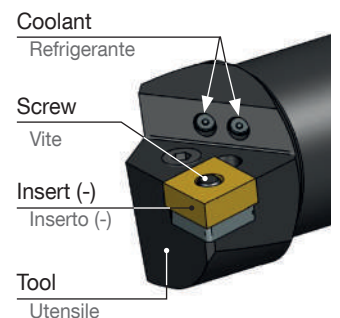
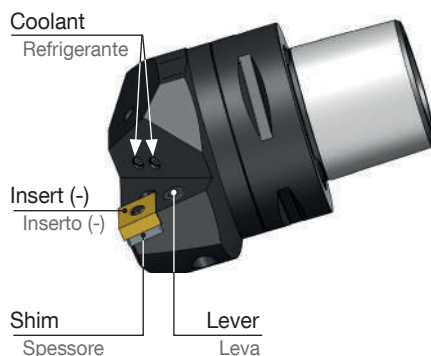
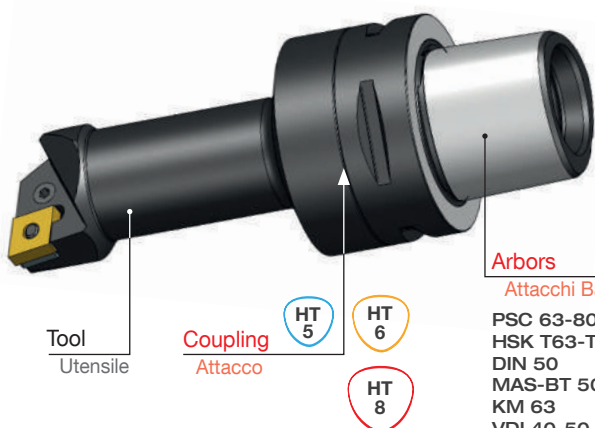

Arbors
Attacchi Base
PSC 63-80-100
HSK T63-T100
DIN 50
MAS-BT 50
KM 63
VDI 40-50

ARBORS (STANDARD) 8

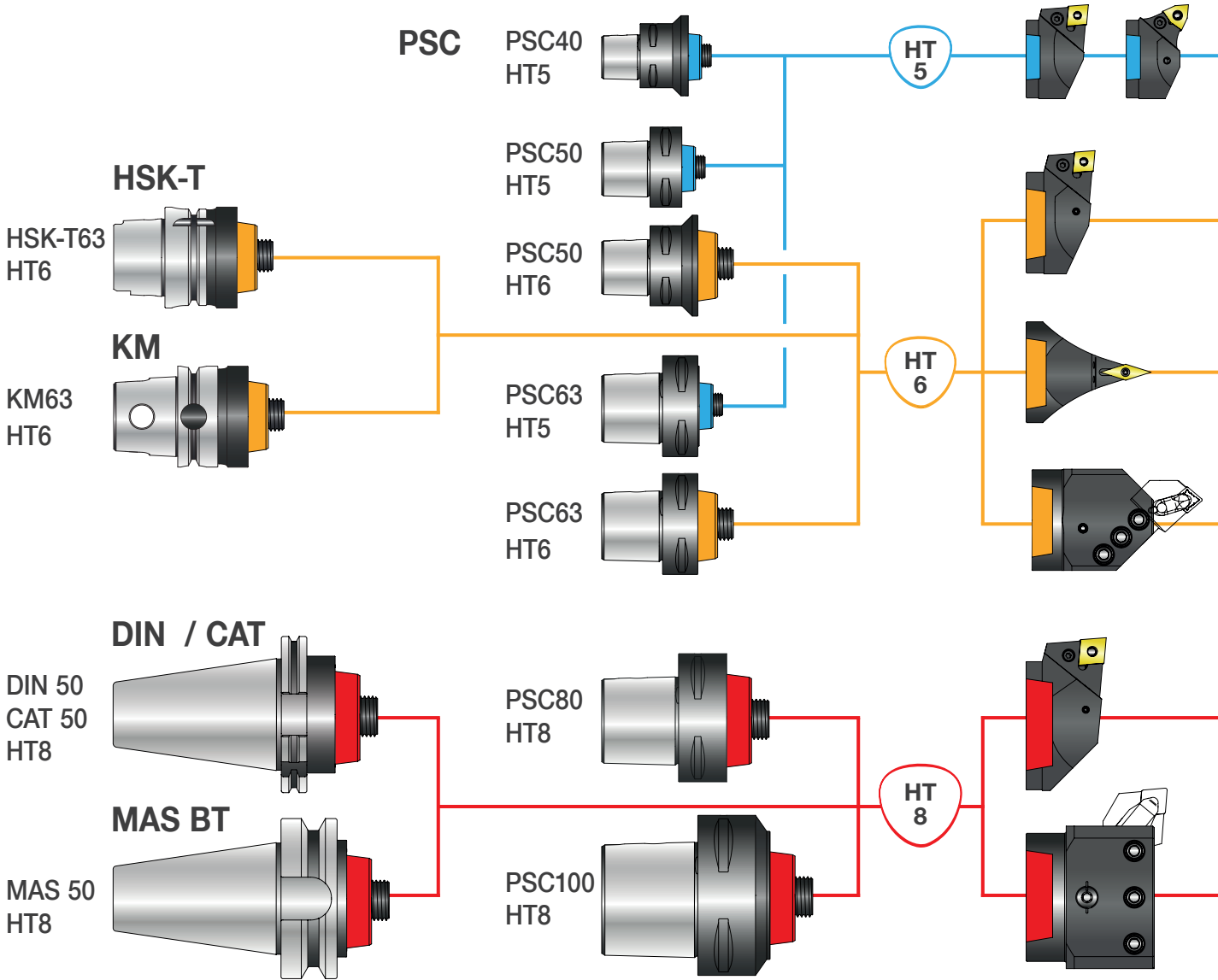

SYSTEM & SOLUTIONS FOR MULTITASKING MACHINES

TOOLS (STANDARD) 10-13

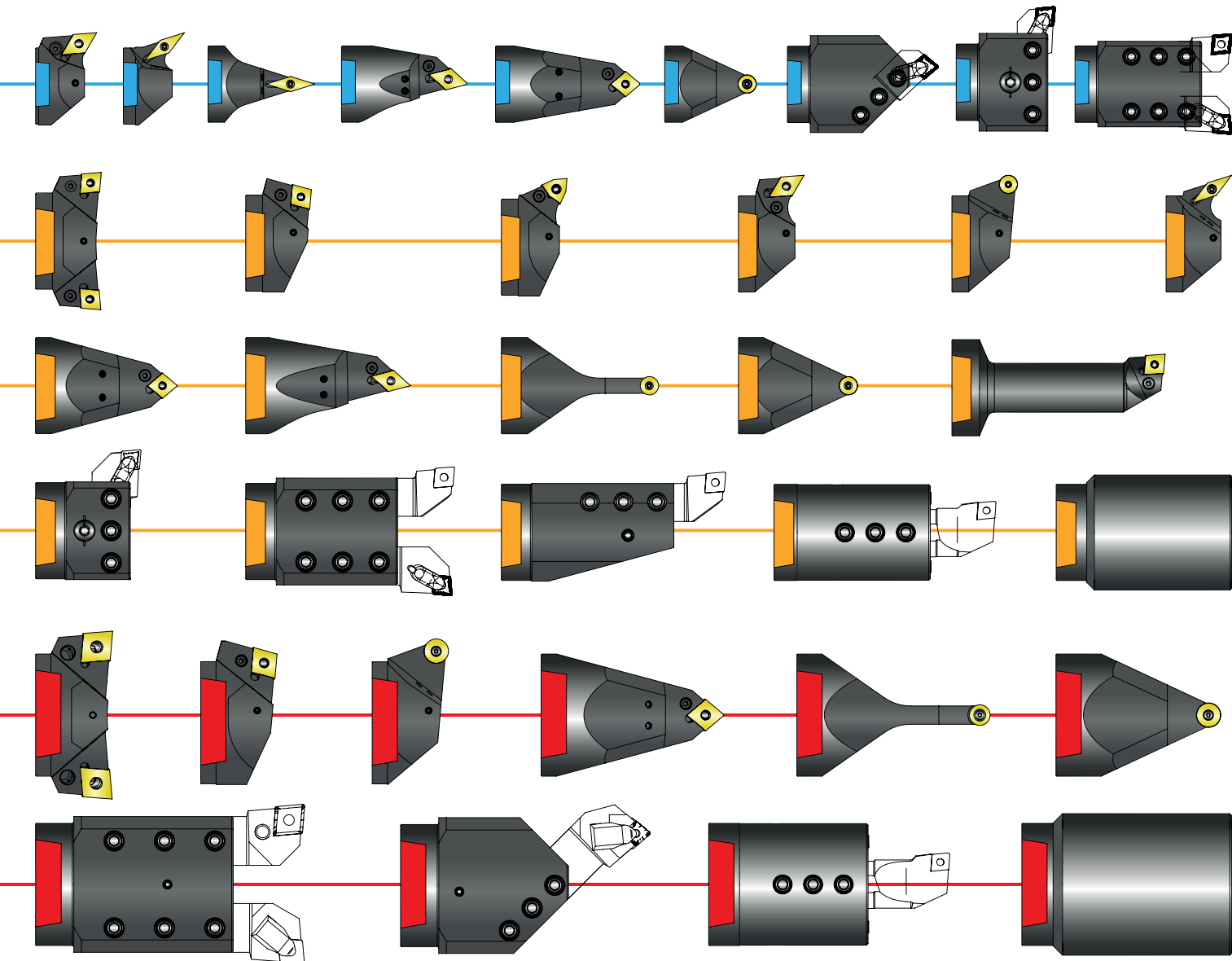

MONOLITHIC TOOLHOLDERS 14-15

MONOforce
POWER MILLING CHUCKS



MONOd
COLLET CHUCK HOLDERS



MONOLITHIC TESTAROSSA MICROMETRIC FINISHING BORING 2µm 16-17

Ø 2,5 - 140

TR50 - PSC40

TR50 - PSC50

TR50 - PSC63



SPARE PARTS
18-19

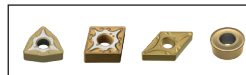

INSERTS
20-23

PSC 40 - HT5

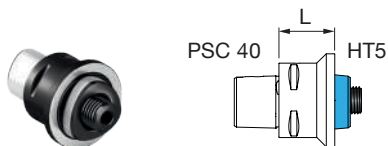

REF.	CODE	L
PSC 40 - HT5.30	41HT15014000	30

PSC 50 - HT5

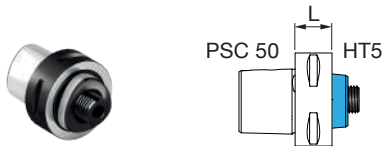

REF.	CODE	L
PSC 50 - HT5.20	41HT15015000	20
PSC 50 - HT5.60	41HT15015001	60
PSC 50 - HT5.100	41HT15015002	100

PSC 50 - HT6

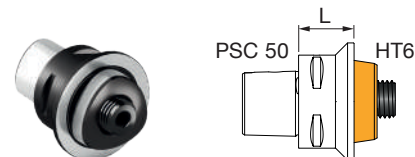

REF.	CODE	L
PSC 50 - HT6.30	41HT16315000	30

PSC 63 - HT5

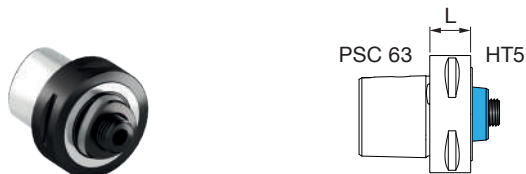

REF.	CODE	L
PSC 63 - HT5.22	41HT15016300	22

PSC 63 - HT6

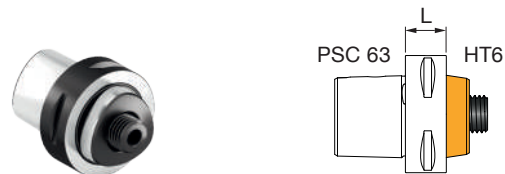

REF.	CODE	L
PSC 63 - HT6.22	41HT16316300	22
PSC 63 - HT6.80	41HT16316301	80
PSC 63 - HT6.130	41HT16316302	130

PSC 80 - HT8

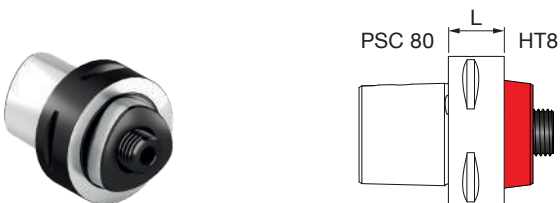

REF.	CODE	L
PSC 80 - HT8.30	41HT18018000	30

PSC 100 - HT8

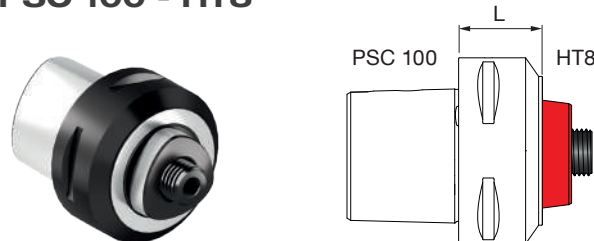

REF.	CODE	L
PSC 100 - HT8.45	41HT18011000	45

HSK-T63 - HT6

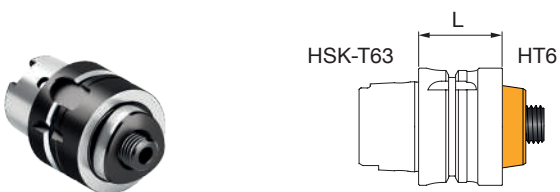

REF.	CODE	L
HSK-T 63 - HT6.45	41HT16346300	45

KM 63 - HT6

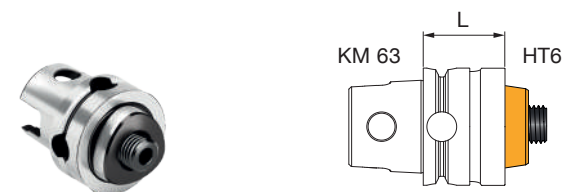

REF.	CODE	L
KM63 - HT6.25	41HT16366300	25

DIN69871 AD50 - HT8



CAT50 - HT8



MAS-BT50 - HT8

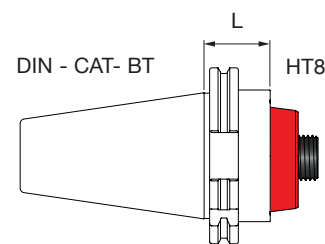

REF.	CODE	L
DIN69871-AD50 - HT8.36.5	41HT18025000	DIN 50 36.5
CAT50 UNC - HT8.50.5	41HT18055000	CAT 50 50.5
MAS403BT-AD50 - HT8.38.5	41HT18035000	BT 50 38.5

 screws included see p.19
viti incluse vedere p.19

VDI 40-50 Upon request - A richiesta

EXTENSIONS-REDUCTIONS - PROLUNGHE-RIDUZIONI

PSC - PR EXTENSIONS - PROLUNGHE

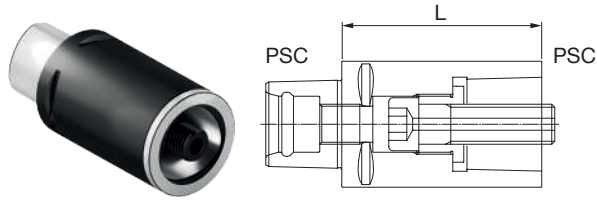

REF.	CODE	L	kg
PR PSC 40.60	656PS04006000	60	0.55
PR PSC 50.80	656PS05008000	80	1.1
PR PSC 63.100	656PS06310000	100	2.2
PR PSC 80.100	656PS08010000	100	3.6

PSC - RD REDUCTIONS -RIDUZIONI

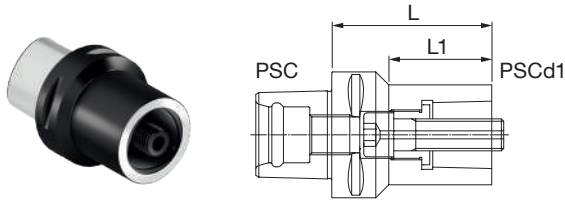

REF.	CODE	PSCd1	L	L1	kg
RD PSC 50/40.65	657PS05004000	40	65	45	0.7
RD PSC 63/40.80	657PS06304000	40	80	51.4	1.3
RD PSC 63/50.80	657PS06305000	50	80	51.5	1.5
RD PSC 80/50.80	657PS08005000	50	80	49.3	2.2
RD PSC 80/63.80	657PS08006300	63	80	53.1	2.5

PSC - MHD' REDUCTIONS -RIDUZIONI

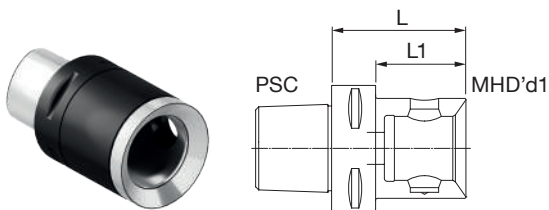

REF.	CODE	MHD'd1	L	L1	kg
PSC 50 - MHD' 50.55	416502605005	50	55		0.8
PSC 63 - MHD' 40.50	416402606305	40	50	28	0.9
PSC 63 - MHD' 50.55	416502606305	50	55	33	0.8
PSC 63 - MHD' 63.77	416632606307	63	77		1.8
PSC 80 - MHD' 50.60	416502608006	50	60	30	2
PSC 80 - MHD' 63.70	416632608007	63	70	40	2.3
PSC 80 - MHD' 80.75	416802608007	80	75		2.6

OTHER STANDARD ARBORS - ALTRI ATTACCHI BASE STANDARD

DIN-AD - PSC

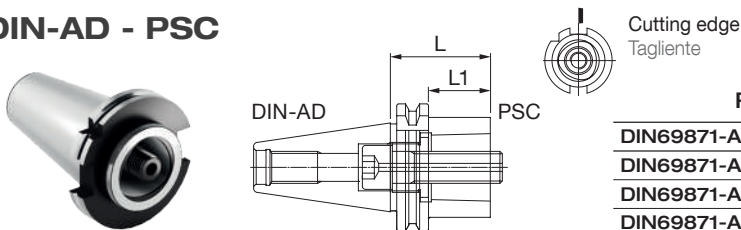

REF.	CODE	PSC	L	L1	kg
DIN69871-AD40 PSC 50.40	41PS05014028	50	40	21	0.9
DIN69871-AD50 PSC 50.30	41PS05015020	50	30	11	2.7
DIN69871-AD50 PSC 63.30	41PS06315028	63	30	11	2.8
DIN69871-AD50 PSC 80.70	41PS08015020	80	70	51	3.7

MAS BT-AD - PSC

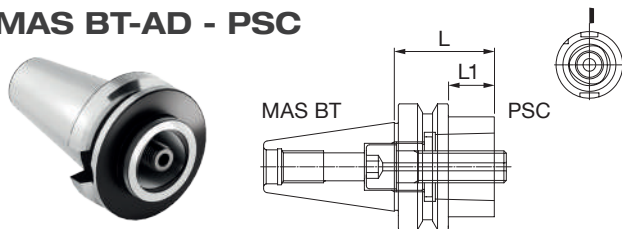

REF.	CODE	PSC	L	L1	kg
MAS403 BT40-AD PSC 50.50	41PS05014032	50	50	23	1.2
MAS403 BT50-AD PSC 50.40	41PS05015030	50	40	2	3.4
MAS403 BT50-AD PSC 63.50	41PS06315032	63	50	12	3.5
MAS403 BT50-AD PSC 80.70	41PS08015030	80	70	32	4

HSK-T - PSC

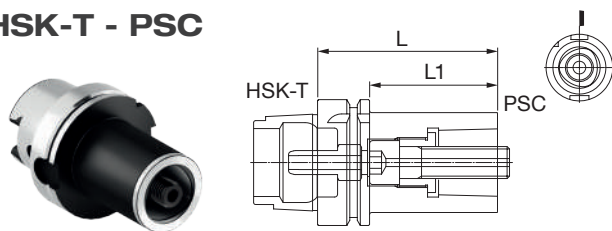

REF.	CODE	PSC	L	L1	kg
HSK-T63 PSC 40.80	41PS0405632T	40	80	54	1.1
HSK-T63 PSC 50.90	41PS0505632T	50	90	64	1.5
HSK-T100 PSC 50.100	41PS0505992T	50	100	71	3
HSK-T100 PSC 63.110	41PS0635992T	63	110	81	3.6
HSK-T100 PSC 80.120	41PS0805992T	80	120	91	4.7

CAT-AD - PSC

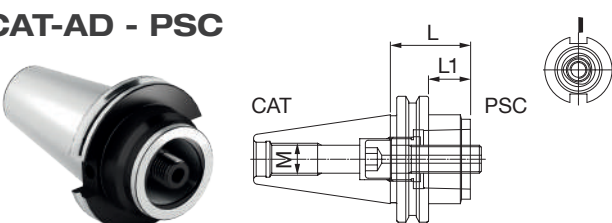

REF.	CODE	PSC	L	L1	M	kg
CAT40 AD PSC 50.50	41PS05014045	50	50	31	UNC 5/8-11	1
CAT50 AD PSC 50.40	41PS05015045	50	40	21	UNC 1-8	2.5
CAT50 AD PSC 63.50	41PS06315045	63	50	31	UNC 1-8	3
CAT50 AD PSC 80.100	41PS08015045	80	100	81	UNC 1-8	4.6

PCLNR

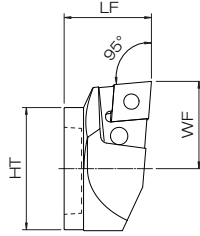

REF.	CODE		LF	WF
THT5 PCLNR 35040-12	7THT5PCLNR30412	CNM...1204...	40	35
THT6 PCLNR 45043-12	7THT6PCLNR40412	CNM...1204...	43	45
THT6 PCLNR 45043-16	7THT6PCLNR40416	CNM...1606...	43	45
THT8 PCLNR 55050-16	7THT8PCLNR50516	CNM...1606...	50	55
THT8 PCLNR 55050-19	7THT8PCLNR50519	CNM...1906...	50	55

PCLNN

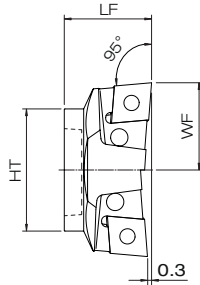

REF.	CODE		LF	WF
THT6 PCLNN 45043-12	7THT6PCLNN40412	CNM...1204...	43	45
THT6 PCLNN 45043-16	7THT6PCLNN40416	CNM...1606...	43	45
THT8 PCLNN 55050-19	7THT8PCLNN50519	CNM...1906...	50	55

PCBNR

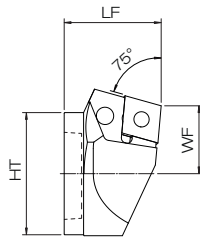

REF.	CODE		LF	WF
THT6 PCBNR 35043-12	7THT6PCBNR30412	CNM...1204...	43	35
THT6 PCBNR 35043-16	7THT6PCBNR30416	CNM...1606...	43	35
THT8 PCBNR 45050-16	7THT8PCBNR40516	CNM...1606...	50	45
THT8 PCBNR 45050-19	7THT8PCBNR40519	CNM...1906...	50	45

PWLNR

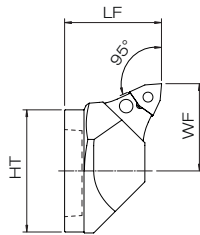

REF.	CODE		LF	WF
THT5 PWLNR 35040-08	7THT5PWLNR30408	WNM...0804...	40	35
THT6 PWLNR 45043-08	7THT6PWLNR40408	WNM...0804...	43	45

PDJNR

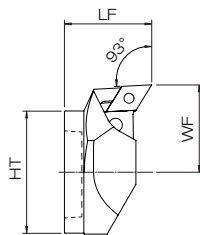

REF.	CODE		LF	WF
THT5 PDJNR 35040-15	7THT5PDJNR30415	DNM...1506...	40	35
THT6 PDJNR 45043-15	7THT6PDJNR40415	DNM...1506...	43	45

SRSCR

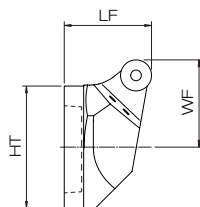

REF.	CODE		LF	WF
THT6 SRSCR 45043-12	7THT6SRSCR40412	RCM...1204...	43	45
THT6 SRSCR 45043-16	7THT6SRSCR40416	RCM...1606...	43	45
THT8 SRSCR 55050-16	7THT8SRSCR50516	RCM...1606...	50	55

SVHBR

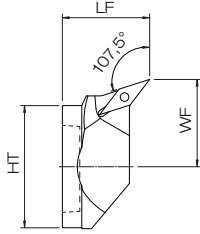

REF.	CODE		LF	WF
THT5 SVHBR 35040-16	7THT5SVHBR30416	VB_...1604...	40	35
THT6 SVHBR 45043-16	7THT6SVHBR40416	VB_...1604...	43	45

SVVBN

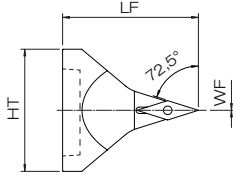

REF.	CODE		LF	WF
THT5 SVVBN 00070-16	7THT5SVVBN00716	VB_...1604...	70	0
THT6 SVVBN 00078 16	7THT6SVVBN00716	VB_...1604...	78	0

PDMNR

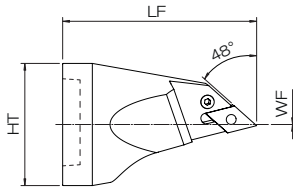

REF.	CODE		LF	WF
THT5 PDMNR 00083-15	7THT5PDMNR00815	DNM...1506...	83	0
THT6 PDMNR 00108-15	7THT6PDMNR01015	DNM...1506...	108	0

PCMNN

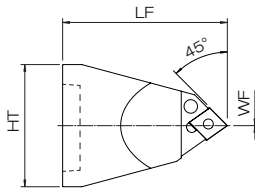

REF.	CODE		LF	WF
THT5 PCMNN 00095-12	7THT5PCMNN00912	CNM...1204...	95	0
THT6 PCMNN 00093-12	7THT6PCMNN00912	CNM...1204...	93	0
THT8 PCMNN 00120-16	7THT8PCMNN01216	CNM...1606...	120	0

SRDCN

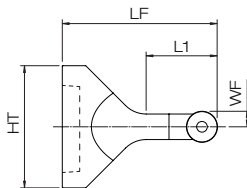

REF.	CODE		LF	L1	WF
THT6 SRDCN 00103-12	7THT6SRDCN01012	RCM...1204...	103	45	6
THT8 SRDCN 00120-16	7THT8SRDCN01216	RCM...1606...	120	55	8

SRDCN

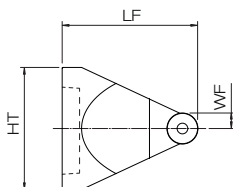

REF.	CODE		LF	WF
THT5 SRDCN 00060-12	7THT5SRDCN00612	RCM...1204...	60	6
THT6 SRDCN 00078-12	7THT6SRDCN00712	RCM...1204...	78	6
THT8 SRDCN 00100-16	7THT8SRDCN01016	RCM...1606...	100	8

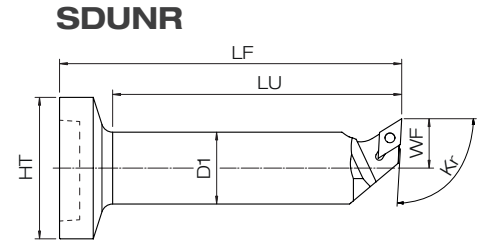
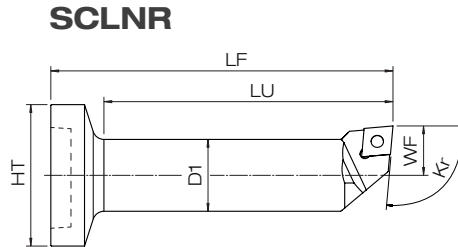
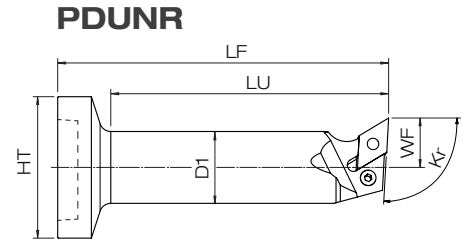
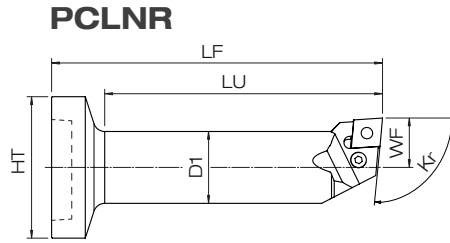

HP High Pressure Coolant 150 BAR
Refrigerante ad alta pressione 150 BAR

REF.	CODE		LF	LU	D1	WF	Kr
THT6 PCLNR 17148-12	7THT6PCLNR11412	CNM...1204...	148	112	25	17	95°
THT6 PCLNR 22178-12	7THT6PCLNR21712	CNM...1204...	178	150	32	22	95°
THT6 PCLNR 27138-12	7THT6PCLNR21312	CNM...1204...	138	110	40	27	95°
THT6 PDUNR 22178-15	7THT6PDUNR21715	DNM...1506...	178	150	32	22	93°
THT6 SCLCR 17148-09	7THT6SCLCR11409	CC... 09T3...	148	120	25	17	95°
THT6 SCLCR 22178-09	7THT6SCLCR21709	CC... 09T3...	178	150	32	22	95°
THT6 SDUCR 17148-11	7THT6SDUCR11411	DCM...11T3...	148	120	25	17	93°
THT6 SDUCR 22178-11	7THT6SDUCR21711	DCM...11T3...	178	150	32	22	93°

D...

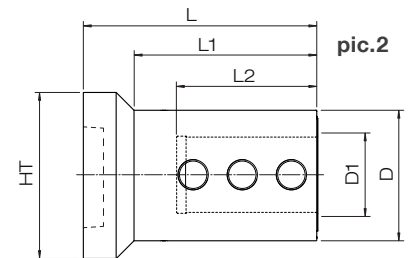
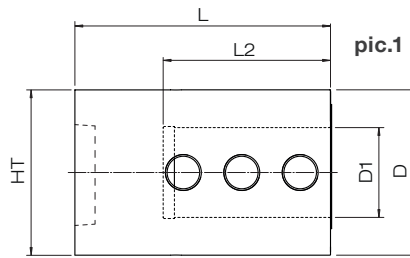

REF.	CODE	L	L1	L2	D	D1	pic.
THT5 D20x72	7THT5D200721	72	-	40	50	20	1
THT6 D25x93	7THT6D250931	93	73	55	56	25	2
THT6 D32x113	7THT6D321131	113	-	70	63	32	1
THT8 D32x115	7THT8D321151	115	-	70	80	32	1
THT8 D40x130	7THT8D401301	130	-	85	80	40	1

NS...

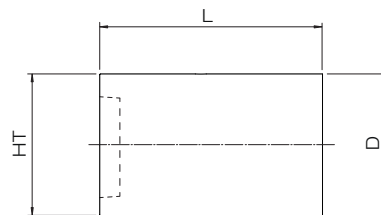
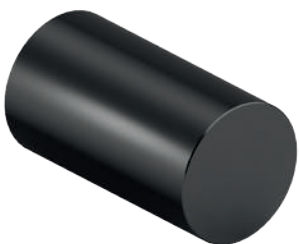

REF.	CODE	L	D
BLANKS HT5 50.80 42HRC	7THT5Z405008	80	50
BLANKS HT6 63.110 42HRC	7THT6Z406311	110	63
BLANKS HT8 80.130 42HRC	7THT8Z408013	130	80

TURNING TOOLS - UTENSILI DI TORNITURA

TU...45 R

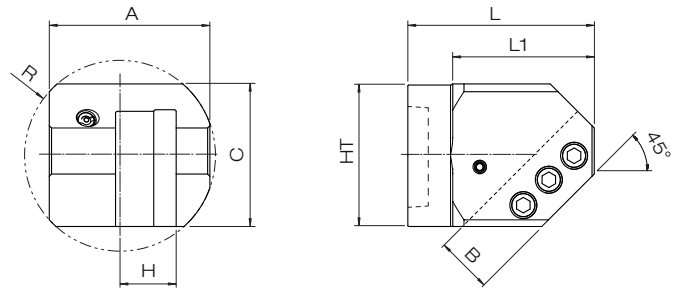

REF.	CODE	L	L1	A	C	R	HxB
THT5 TU20.45R	7THT5T2045R1	80	65	68	63.5	40	20x20
THT6 TU25.45R	7THT6T2545R1	83	63	72	64	42.5	25x25
THT8 TU32.45R	7THT8T3245R1	110	85	98.5	89	57.5	32x32

TU...90...

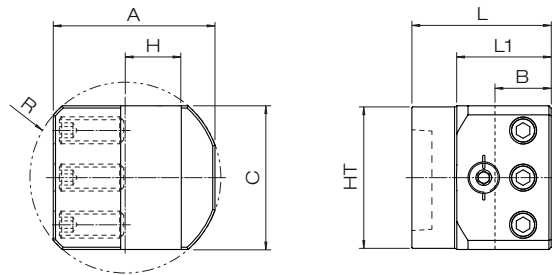

REF.	CODE	L	L1	A	C	R	HxB
THT5 TU20.90	7THT5T209001	60	45	65	64	40	20x20
THT6 TU25.90	7THT6T259001	62	42	72	64	42.5	25x25
THT8 TU32.90	7THT8T329001	80	55	98	89	57.5	32x32

TU...02...

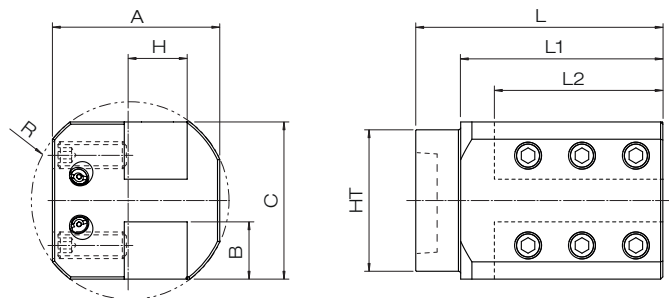

REF.	CODE	L	L1	L2	A	C	R	HxB
THT5 TU20.02	7THT5T200201	90	75	60	65	56	37.5	20x20
THT6 TU25.02	7THT6T250201	110	90	75	74.5	70	44	25x25
THT8 TU32.02	7THT8T320201	140	115	95	98.5	89	57.5	32x32

TU...01 R/L



RIGHT Assembly
Montaggio DESTRO

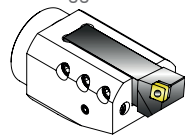

LEFT Assembly
Montaggio SINISTRO

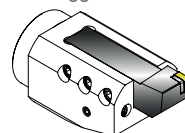

3 locking screws on both sides
3 viti di bloccaggio su entrambi i lati

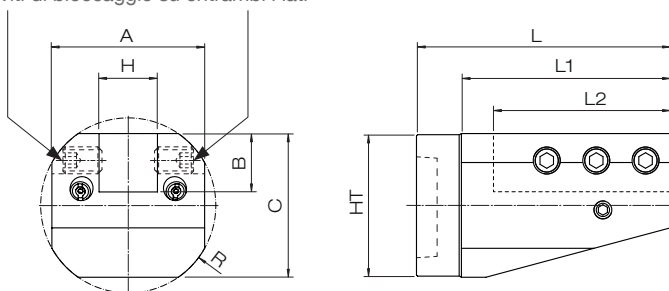

REF.	CODE	L	L1	L2	A	C	R	HxB
THT5 TU20.01 R/L	7THT5T200101	90	75	60	60	56	37.5	20x20
THT6 TU25.01 R/L	7THT6T250101	113	93	75	68	64	39	25x25

POWER MILLING CHUCKS - PORTAUTENSILI FORTE SERRAGGIO

MONOforce high-precision ultra-tight toolholders are designed for both rough milling and precision finishing operations. Manufactured according to the most widely adopted machine spindle standards, they offer a versatile clamping range from Ø3 mm to Ø25 mm when used with RC reduction collets (standard and sealed). All MONOforce toolholders are balanced to class G 6.3 at 15,000 rpm.

I portautensili **MONOforce**, ad alta precisione e forte serraggio, sono adatti sia alle lavorazioni di sgrossatura sia a quelle di finitura di precisione. Realizzati secondo gli standard più diffusi dei mandrini macchina consentono, tramite l'impiego delle bussole di riduzione RC (standard e a tenuta), un range d'impiego da Ø 3mm a Ø 25mm. Tutti i portautensili MONOforce sono equilibrati in classe G 6,3 a 15.000 giri/min.

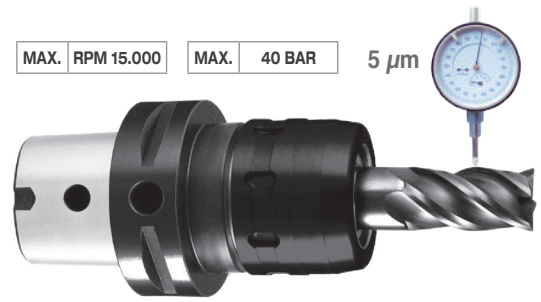

PSC - FORCE

MILLING POWER CHUCKS - FORTE SERRAGGIO

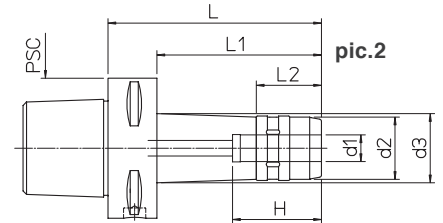
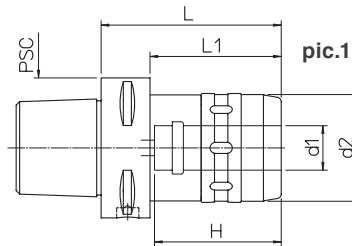

Without clamping wrench - Chip prearrangement
Chiave di serraggio esclusa - Predisposizione Chip

PSC	REF.	CODE	d1	d2	d3	H	L	L1	L2	kg	pic.
63	PSC 63 - MF 12.100	71PSC-063MF1210	12	28	31.5	46	100	78	29.5	1.4	2
63	PSC 63 - MF 20.80	71PSC-063MF2008	20	48		60	80	58		1.3	1
63	PSC 63 - MF 32.100	71PSC-063MF3210	32	66		80	100			2.1	1
80	PSC 80 - MF 20.80	71PSC-080MF2008	20	48		60	80	50		3.7	1
80	PSC 80 - MF 32.100	71PSC-080MF3210	32	66		80	100	70		4.4	1

RC

BUSHES ULTRA-TIGHT SPINDLE - BUSSOLE MANDRINO A FORTE SERRAGGIO

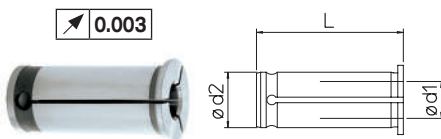

RC SEALED bushes on request
A richiesta bussole RC a TENUTA

Ø d2 = 12

REF.	CODE	d1	L
RC12.03	497080012030	3	44
RC12.04	497080012040	4	44
RC12.06	497080012060	6	44
RC12.08	497080012080	8	44
RC12.10	497080012100	10	44

Ø d2 = 20

REF.	CODE	d1	L
RC20.03	497080020030	3	50
RC20.04	497080020040	4	50
RC20.05	497080020050	5	50
RC20.06	497080020060	6	50
RC20.08	497080020080	8	50
RC20.10	497080020100	10	50
RC20.12	497080020120	12	50
RC20.14	497080020140	14	50
RC20.16	497080020160	16	50

Ø d2 = 32

REF.	CODE	d1	L
RC32.03	497080032030	3	63
RC32.04	497080032040	4	63
RC32.05	497080032050	5	63
RC32.06	497080032060	6	63
RC32.08	497080032080	8	63
RC32.10	497080032100	10	63
RC32.12	497080032120	12	63
RC32.14	497080032140	14	63
RC32.16	497080032160	16	63
RC32.18	497080032180	18	63
RC32.20	497080032200	20	63
RC32.25	497080032250	25	63

PSC - KIT K01 MONOforce 20-32



MF 20

- 1 RC 20.06 1 RC 20.12
- 1 RC 20.08 1 RC 20.16
- 1 RC 20.10 1 CHV 50



MF 32

- 1 RC 32.06 1 RC 32.16
- 1 RC 32.08 1 RC 32.20
- 1 RC 32.10 1 RC 32.25
- 1 RC 32.12 1 CHV 75

PSC	REF.	CODE	kg
63	KIT K01 MONOFORCE 20.80 PSC63	7KPSC-063MF2008	2.3
63	KIT K01 MONOFORCE 32.100 PSC63	7KPSC-063MF3210	4.6
80	KIT K01 MONOFORCE 20.80 PSC80	7KPSC-080MF2008	5.4
80	KIT K01 MONOFORCE 32.100 PSC80	7KPSC-080MF3210	7.5

MONOLITHIC TOOLHOLDERS - PORTAUTENSILI MONOLITICI

MONOd' monolithic ER collet-chuck holders are manufactured according to ISO 26623 interfaces. Each toolholder is produced from high-quality materials to ensure long-term reliability and repeatability. All toolholders are balanced to class G 6.3, guaranteeing optimal performance up to 15,000 rpm.

I portapinze ER monolitici **MONOd'** sono realizzati secondo gli attacchi standard ISO 26623. Ogni portautensile è prodotto con materiali di alta qualità per garantire affidabilità e ripetibilità nel lungo periodo.

Tutti i portautensili sono equilibrati in classe G 6,3, assicurando prestazioni ottimali fino a 15.000 giri/min.

MAX. RPM 15.000  0.003



PSC - ER

COLLETS CHUCKING TOOLS - ADATTATORI PER PINZE ELASTICHE

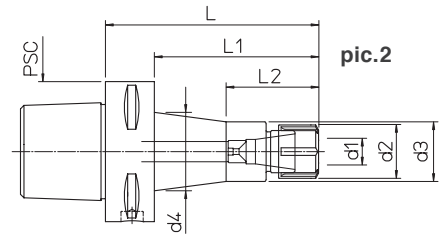
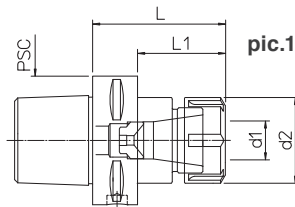

Supplied without collets and clamping wrenches - Chip prearrangement
Pinze elastiche e chiavi di serraggio escluse - Predisposizione Chip

PSC	REF.	CODE	ER	d1	d2	d3	d4	L	L1	L2	kg	pic
50	PSC50 - ER16.55	71PSC-050ER1605	16M	0.5-10	22	24		55	35	26	0.5	2
50	PSC50 - ER25.65	71PSC-050ER2506	25	1-16	42			65	45		0.8	1
63	PSC63 - ER16.60	71PSC-063ER1606	16M	0.5-10	22	24		60	38		0.85	2
63	PSC63 - ER16.120	71PSC-063ER1612	16M	0.5-10	22	24	31	120	98	33	1.1	2
63	PSC63 - ER25.65	71PSC-063ER2506	25	1-16	42			65	43	37	1.1	1
63	PSC63 - ER25.140	71PSC-063ER2514	25	1-16	42		47.5	140	118	43.5	1.9	2
63	PSC63 - ER32.75	71PSC-063ER3207	32	2-20	50			75	53		1.5	1
63	PSC63 - ER32.160	71PSC-063ER3216	32	2-20	50			160	138		2.5	1
80	PSC80 - ER25.70	71PSC-080ER2507	25	1-16	42			70	40		2.1	1
80	PSC80 - ER32.75	71PSC-080ER3207	32	2-20	50			72	45		2.5	1

ER COLLETS - PINZE ER

ER DIN 6499-B



 0.01

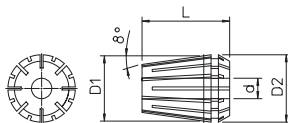

REF.	d	D1	D2	L
ER 16	0.5 ~ 10	16	17	27.5
ER 25	1 ~ 16	25	26	34
ER 32	2 ~ 20	32	33	40

RANGE	CODE ER16	CODE ER25	CODE ER32
1 - 0.5	496080116010		
1.5 - 1	496080116015		
2 - 1		496080125020	
2 - 1.5	496080116021		
2.5 - 2	496080116025		
3 - 2	496080116030	496080125030	496080132030
4 - 3	496080116040	496080125040	496080132040
5 - 4	496080116050	496080125050	496080132050
6 - 5	496080116060	496080125060	496080132060
7 - 6	496080116070	496080125070	496080132070
8 - 7	496080116080	496080125080	496080132080
9 - 8	496080116090	496080125090	496080132090
10 - 9	496080116100	496080125100	496080132100
11 - 10		496080125110	496080132110
12 - 11		496080125120	496080132120
13 - 12		496080125130	496080132130
14 - 13		496080125140	496080132140
15 - 14		496080125150	496080132150
16 - 15		496080125160	496080132160
17 - 16			496080132170
18 - 17			496080132180
19 - 18			496080132190
20 - 19			496080132200

ER collets SEALED on request - A richiesta pinze ER a TENUTA

SET ER



REF.	Ø	CODE
SET ER16/10	0.5 ~ 10	496080116000
SET ER25/15	1 ~ 16	496080125000
SET ER32/18	2 ~ 20	496080132000

MICROMETRIC FINE BORING HEADS - TESTE MICROMETRICHE DI FINITURA

PSC-TRM50 heads allow high precision machining and excellent surface finish in the **IT6** tolerance class. The adjustment sensitivity of **1 micron on the radius** is easily readable on the vernier scale and can also be performed in the machine spindle.

Le testine PSC-TRM50 consentono lavorazioni ad alta precisione e ottima finitura superficiale in tolleranze di grado **IT6**. La sensibilità di regolazione di **1 micron sul raggio** è facilmente leggibile sul nonio ed eseguibile anche in macchina.

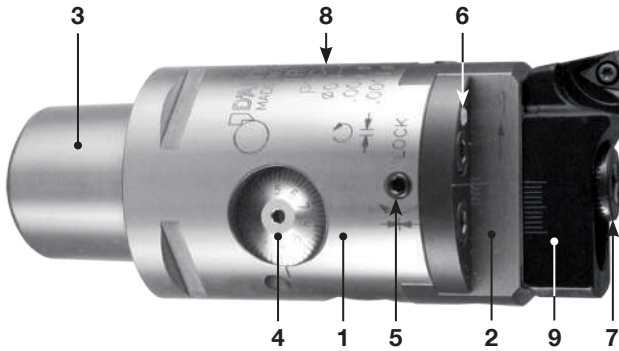

Ø 2.5 ~ 140

1µm

- | | |
|------------------------------|-----------------------------------|
| 1. Body | 1. Corpo |
| 2. Slide toolholder | 2. Slitta portautensili |
| 3. PSC 40-50-63 | 3. PSC 40-50-63 |
| 4. Micrometric vernier scale | 4. Nonio micrometrico |
| 5. Slide clamp screw | 5. Vite bloccaggio slitta |
| 6. Coolant outlet Max BAR 40 | 6. Uscita refrigerante Max BAR 40 |
| 7. Tools clamp screws | 7. Viti bloccaggio utensili |
| 8. Oiler | 8. Oliatore |
| 9. Bit holder | 9. Seggio portainserti |

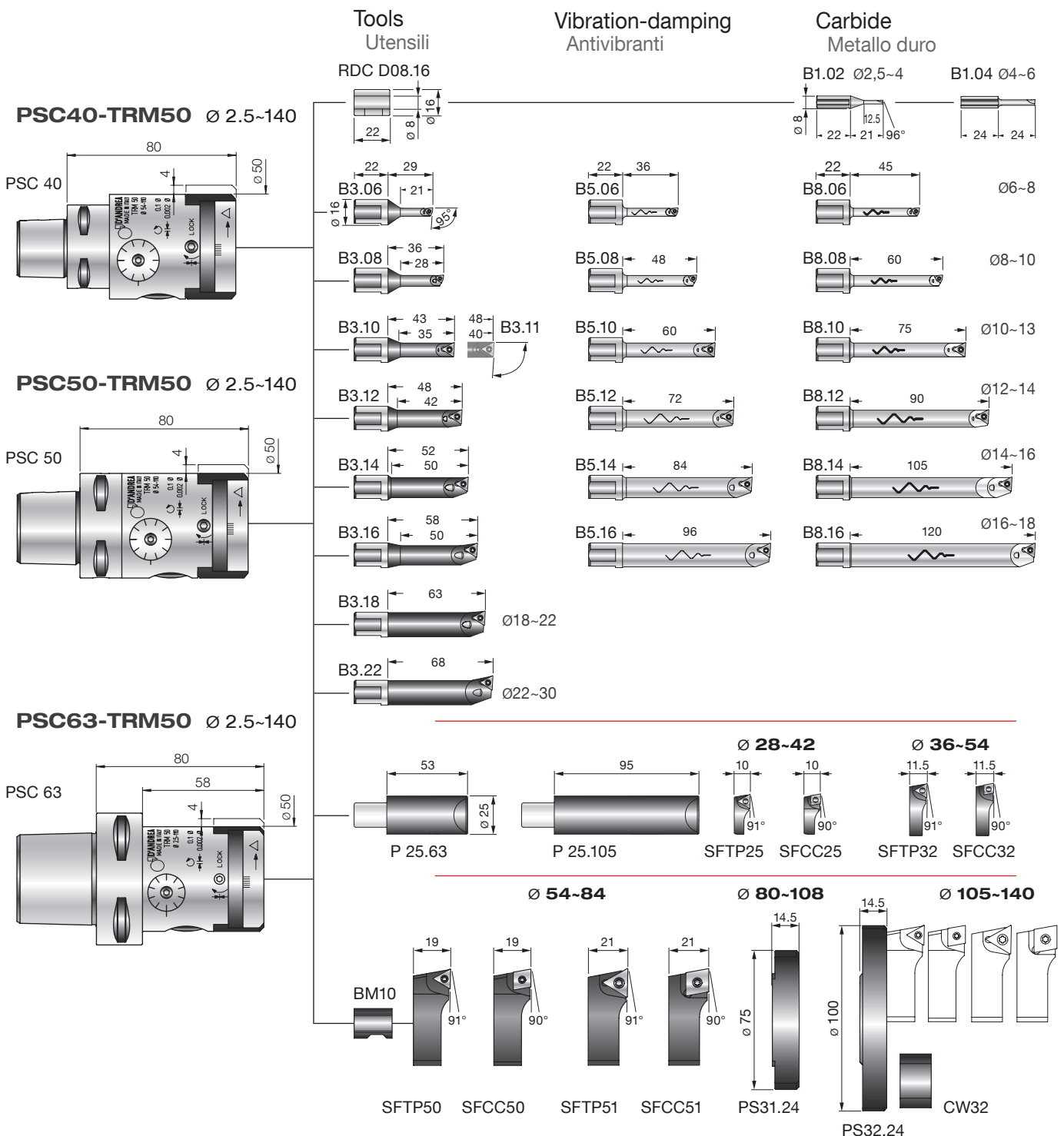

KIT K01 PSC40-TRM50 / KIT K01 PSC50-TRM50 / KIT K01 PSC63-TRM50

Ø 6 ~ 140



- 1 B3.06 1 SFTP25
- 1 B3.08 1 SFTP32
- 1 B3.11 1 SFTP50
- 1 B3.16 1 P 25.63
- 1 B3.22 1 PS 31.24
- 1 CW 32 1 PS 32.24
- 5 TPGX 090202L DC100
- 1 TPGX 110302L DC100
- 2 WCGT 020102L DC100

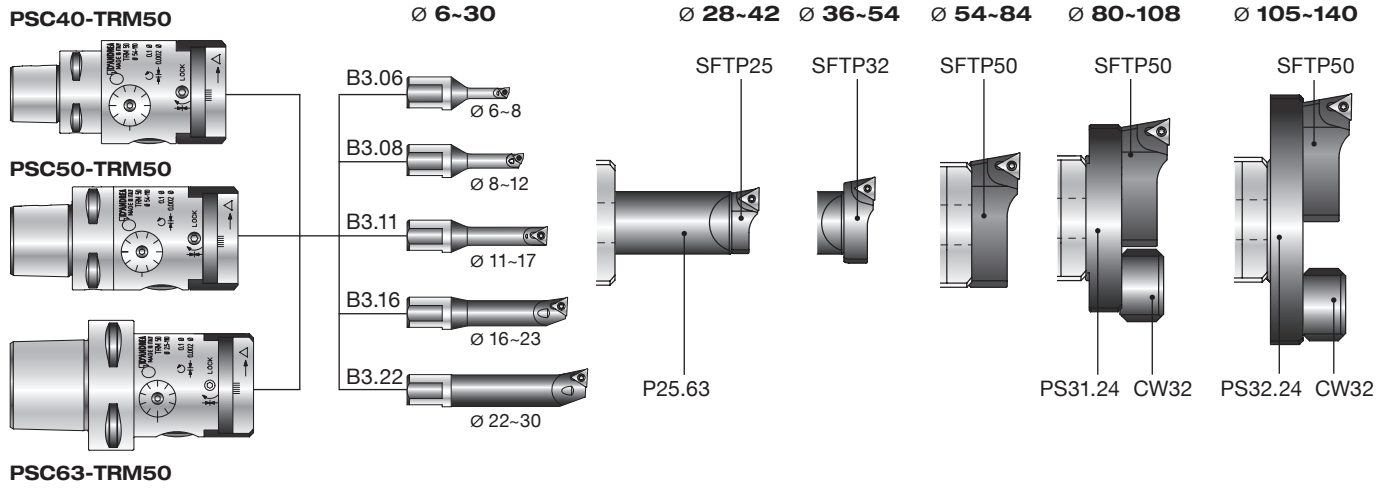

REF.	CODE	kg
PSC40-TRM50	71PSC040TR50080	0.9
PSC50-TRM50	71PSC050TR50080	1.1
PSC63-TRM50	71PSC063TR50080	1.3
KIT K01 PSC40-TRM50	7KPSC040TR50081	2.8
KIT K01 PSC50-TRM50	7KPSC050TR50081	3.5
KIT K01 PSC63-TRM50	7KPSC063TR50081	4.2

REF.	CODE	kg
D08.16	200560116082	0.02
P25.63	435116250631	0.5
P25.105	435116251051	0.8
PS 31.24	433024140751	0.19
PS 32.24	433024141001	0.2
CW 32	392011003201	0.07

REF.	CODE	TORX T	kg
B1.02	572010502001		0.02
B1.04	572010504001		0.02
B3.06	572010506001	WCGT0201.. TS 21 06	0.035
B3.08	572010508001	WCGT0201.. TS 211 06	0.4
B3.10	572010510001	TPGX0902.. CS 250 T 08	0.05
B3.11	572010511001	TPGX0902.. CS 250 T 08	0.055
B3.12	572010512001	TPGX0902.. CS 250 T 08	0.06
B3.14	572010514001	TPGX0902.. CS 250 T 08	0.07
B3.16	572010516001	TPGX0902.. CS 250 T 08	0.07
B3.18	572010518001	TPGX0902.. CS 250 T 08	0.1
B3.22	572010522001	TPGX0902.. CS 250 T 08	0.1

REF.	CODE	TORX T	kg
B5.06	572010506105	WCGT0201.. TS 21 06	0.075
B5.08	572010508105	WCGT0201.. TS 211 06	0.09
B5.10	572010510105	TPGX0902.. CS 250 T 08	0.1
B5.12	572010512105	TPGX0902.. CS 250 T 08	0.1
B5.14	572010514105	TPGX0902.. CS 250 T 08	0.2
B5.16	572010516105	TPGX0902.. CS 250 T 08	0.3
B8.06	572010506108	WCGT0201.. TS 21 06	0.065
B8.08	572010508108	WCGT0201.. TS 211 06	0.08
B8.10	572010510108	TPGX0902.. CS 250 T 08	0.1
B8.12	572010512108	TPGX0902.. CS 250 T 08	0.2
B8.14	572010514108	TPGX0902.. CS 250 T 08	0.2
B8.16	572010516108	TPGX0902.. CS 250 T 08	0.3

REF.	CODE	TORX T	kg
SFTP25	470500525001	TPGX0902.. CS 250T 08	0.01
SFTP32	470500532001	TPGX0902.. CS 250T 08	0.02
SFTP50	470500550001	TPGX1103.. CS300890T 08	0.08
SFTP51	470500550003	TCMT16T3.. TS 4 15	0.09

REF.	CODE	TORX T	kg
SFCC25	470500525002	CCGT0602.. TS 25 08	0.01
SFCC32	470500532002	CCGT0602.. TS 25 08	0.02
SFCC50	470500550002	CCGT09T3.. TS 4 15	0.08
SFCC51	470500550004	CCMT1204.. TS 5 25	0.09

PCLNR
(*) see exceptions
vedi eccezioni

PCLNN
PCBNR
PCMM

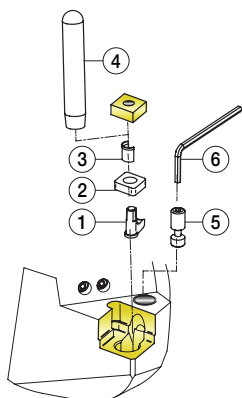

CNM.. CNM.. CNM..
1204.. 1606.. 1906..

PDJNR
PDMNR
PDUNR

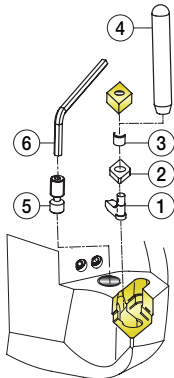

DNM..
1506..

PWLNR

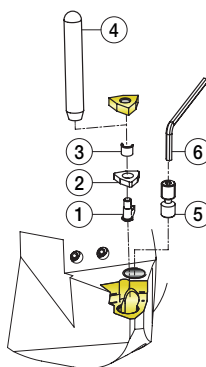

WNM..
0804..

SVHBR
SVVBN

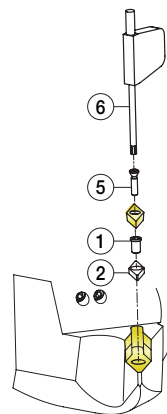

VB..
1604..

SCSCR
SRDCN

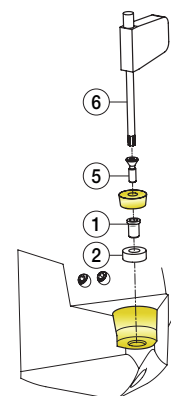

RCM.. RCM..
1204.. 1606..

REF.	CODE 1	CODE 2	CODE 3	CODE 4	CODE 5	CODE 6
CNM..1204..	491110000004	492030003014	100655065061	101501307101	494310080231	101500100300
CNM..1606..	491111160601	492031160601	100655080094	101501307101	494310080261	101500100300
CNM..1906..	491111190601	492031190601	100655095113	101501301408	494311190601	101500100400
DNM..1506..	491110000005	492030003017	100655065061	101501307100	494310080262	101500100400
WNM..0804..	491110000004	492030003020	100655065061	101501307100	494310080231	101500100300
VB..1604..	492010000509	492030003018	-	-	494210035071	101500901500
RCM..1204..	492010000509	492030003019	-	-	494210035071	101500901500
RCM..1606..	492014160601	492034160602	-	-	494214160601	101500902000

(*) THT6 PCLNR 17148-12

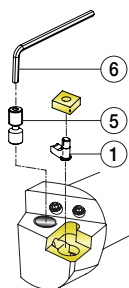

CNM..
1204..

SCLCR

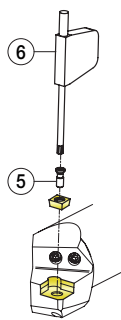

CC..
09T3..

SDUCR

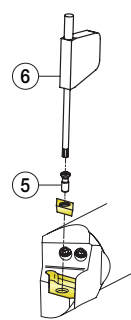

DCM..
11T3..

REF.	CODE 1	CODE 2	CODE 3	CODE 4	CODE 5	CODE 6
CNM..1204..	491110000006	-	-	-	494310080232	101500100250
CC..09T3..	-	-	-	-	494214160602	101500901500
DCM..11T3..	-	-	-	-	494214160602	101500901500

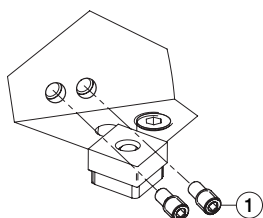

CODE 1	REF.	REF.	REF.	REF.	REF.	REF.	REF.
200100180415	PCLNR/L	PCLNN/L	PCBNR/L	PDJNR/L	SVHBR/L	SRDCR/L	PWLNR/L
	PDMNL/R	PCMNN	SVVBN	SRDCN	PDUNR/L	SCLCR/L	SDUCR/L

TU...45...

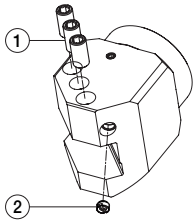

REF.	CODE 1	CODE 2
THT5 TU20.45R	100231100020	382015008004
THT6 TU25.45R	100231120020	382015008004
THT8 TU32.45R	100231120025	382015008004

TU...90...

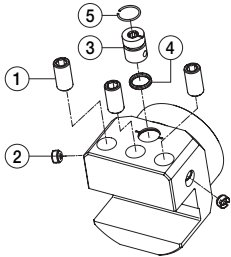

REF.	CODE 1	CODE 2	CODE 3	CODE 4	CODE 5
THT5 TU20.90	100231100016	382015008004	201462501402	101251002043	100900301400
THT6 TU25.90	100231120020	382015008004	201462501401	101251002043	100900301400
THT8 TU32.90	100231120025	382015008004	201462501401	101251002043	100900301400

TU...02...

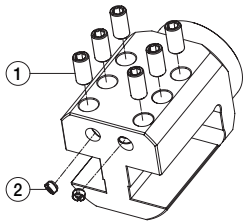

REF.	CODE 1	CODE 2
THT5 TU20.02	100231100016	382015008004
THT6 TU25.02	100231120020	382015008004
THT8 TU32.02	100231120025	382015008004

TU...01 R/L

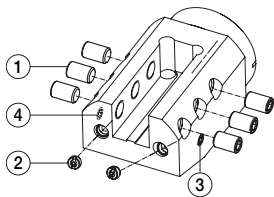

REF.	CODE 1	CODE 2	CODE 3	CODE 4
THT5 TU20.01 R/L	100231100016	382015008004	100231060006	100231060012
THT6 TU25.01 R/L	100231120016	382015008004	100231080008	100231080016

D...

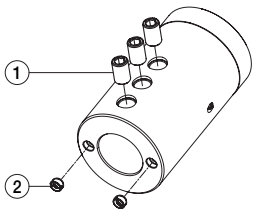

REF.	CODE 1	CODE 2
THT5 D20x72	100231100012	382015008004
THT6 D25x93	100231120014	382015008004
THT6 D32x113	100231120016	382015008004
THT8 D32x115	100231120020	382015008004
THT8 D40x130	100231120020	382015008004

VBC HT...

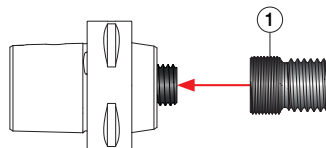

REF.	CODE 1
PSC 40 - HT5.30	201081520004
PSC 50 - HT5.20	201081520004
PSC 50 - HT5.60	201081520005
PSC 50 - HT5.100	201081520006
PSC 50 - HT6.30	201081522011
PSC 63 - HT5.22	201081520004

REF.	CODE 1
PSC 63 - HT6.22	201081522011
PSC 63 - HT6.80	201081522012
PSC 63 - HT6.130	201081522013
PSC 80 - HT8.30	201081527001
PSC 100 - HT8.45	201081527001

REF.	CODE 1
HSK-T 63 - HT6.45	201081522011
KM63 - HT6.25	201081522011
DIN69871-AD50 - HT8.36.5	201081527003
CAT50 UNC - HT8.50.5	201081527002
MAS403BT-AD50 - HT8.38.5	201081527003